

GTC250A-TC

Aero-Derivative Gas Turbine Control

Applications

The GTC250A-TC is specifically designed to control aero-derivative-type dual-shaft gas turbines. It includes field proven OEM-conforming fuel control algorithms for single- or dual-fuel turbines used in generator drive or mechanical drive applications. Typical applications include:

- Generation—Base Loading, Peaking, Stand-by, and Marine
- Compression—Gas Processing, Gas Production, and Pipeline Pumping
- Combined Heat and Power (CHP)
- Combined Cycle Power Generation
- Mechanical and Marine Propulsion Drives

Speed, load, and temperature algorithms maintain precise fuel control within the turbine's operating limits over the entire range of turbine operation, as well as during unforeseen operational disturbances, to provide safe, reliable gas turbine system control. The controller's special PID-to-PID transfer logic allows stable control during normal operations and bumpless control mode transfers during plant upsets, minimizing process over- or undershoot conditions. The unit's environmental specifications allow it to be mounted close to the turbine package for increased critical control-signal reliability.

The GTC250A-TC is field-configurable and ideal for retrofits where it is desired to upgrade the turbine control with a field-proven product and have the flexibility to make site-specific changes as necessary.

The GTC250A-TC contains core fuel control functionality, but can also incorporate all the required Turbine Control (TC) system functions into one unit.

The GTC250A-TC also has the capability for users to add start/stop sequencing routines and site-specific I/O along with any associated logic to meet local functionality needs as well as power generation control.

The GTC250A-TC provides users with a low-risk controller that allows them to benefit from its well tested gas turbine algorithms and hardware, while having the flexibility to add customized logic and I/O as needed, both internally or externally.

Description

The GTC250A-TC is built on Woodward's industrial-hardened Atlas-II™ platform, and include a standard, field-configurable, core fuel control system that controls turbine speed, load, start ramp, temperature, fuel valve position, and fuel transfers for dual-fuel applications.

The GTC250A-TC control software architecture contains two major sections: a standard core engine control that contains core fuel control functions which are protected but can be configured with site-specific values, and an integral interface that allows site-specific control logic and functionality such as: start/stop sequencing, protective monitoring, or other site-specific control requirements to be added and managed as needed using either Woodward's Ladder Logic programming tool, GAP™ programming language, or in an external PLC or DCS controller. Additional site-specific I/O can be added/connected using spare onboard I/O or utilizing remote distributed I/O via the unit's deterministic Ethernet, Profibus, or Modbus* communications. Woodward's service interface software allows the user to view and tune system variables. Data logging files are included to facilitate troubleshooting, and non-volatile counter/timer files keep track of starts, fired hours, and other useful data.

*—Modbus is a trademark of Schneider Automation Inc.



- Field-proven fuel control algorithms
- Low cost—sensible alternative to a general purpose PLC
- Deterministic update rates as fast as 5 ms
- Profibus distributed I/O capability
- Multiple communications protocols:
 - ✓ Modbus®
 - ✓ Ethernet TCP/IP
 - ✓ Ethernet UDP
 - ✓ OPC (Ethernet)
 - ✓ DDE (Dynamic Data Exchange)
 - ✓ CANopen
- High-speed data logging and trending troubleshooting tools
- Non-volatile counters & timers file
- Scalable from core fuel control to total package control
- Programmable in GAP™ and Woodward Ladder Logic environment
- CE and UL Compliant; Marine Type Approved
- SNTP Compliant for time synchronization

The hardware lends itself to bulkhead mounting. Environmental specifications allow the GTC250A-TC to move out of the control room and closer to the prime mover. In many cases, they can be mounted on the prime mover skid. Typically, they are mounted in an enclosure rated for the site-specific environmental conditions. A variety of computational and I/O signals are available to meet the specific needs of the application. Internally, the configuration of the printed circuit board stacks eliminates the need for a motherboard; reducing overall cost. Wiring terminations are provided on the top and bottom edges of the printed circuit boards by means of quick disconnect plug and socket connectors. Control power is supplied from an external 24 Vdc source.

Functionality

Core Fuel Control

- Start fuel ramp
- Dual-shaft speed sensing (w/ redundant probes)
- Gas generator (GG) speed derivative (acceleration & deceleration) control
- Power turbine (PT) and GG speed control
- Remote PT and GG speed reference logic
- Process control on PT speed control
- Load control
- Exhaust gas temperature (EGT) monitoring (1–18 T/C inputs)
 - ✓ Use of all T/Cs, including protection T/Cs
 - ✓ Auto rejection with deviation from average spread
 - ✓ Highest and lowest EGT T/C
- EGT limiting control
- Ambient temperature sensing
- Compressor discharge pressure (CDP or PCD) control
- Flame detection logic (temp, discrete in, or analog in)
- MW load limiting control (selectable)
- Single-fuel or dual-fuel operation with fuel transfer logic
- Overspeed detection/protection

Optimized On-board I/O

- High-speed and deterministic update times
- High CMRR and control-specific filtering result in high degree of noise immunity
- 15 bit resolution differential inputs, allowing very precise control
- I/O is accurate across temperature range
- I/O is isolated in groups to prevent ground loops and other induced noise issues

Fuel Valve Interfacing

- Direct to Woodward's standard valve offerings using CANopen
- Via Woodward's SPC Servo Position Controller to most existing systems for integrating actuators
- Configurable 4–20 or 0–200 mA proportional drivers (2)

Distributed I/O Interface and Possible Sequencing Logic

- Serial RS-232, RS-422, or RS-485
- Ethernet (10/100 MBaud)
- CANopen
- Profibus DP (12 MBaud)

Communications Protocols

- Modbus (RTU and ASCII) over serial or Ethernet
- Ethernet TCP/IP
- Ethernet UDP/IP
- CANopen
- OPC DA 3.0 and AE 1.0

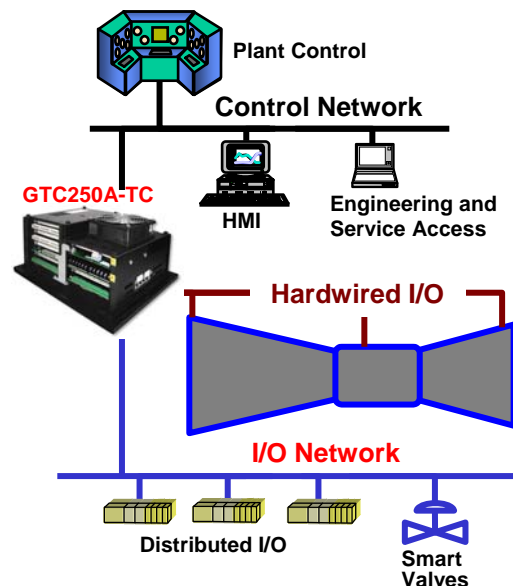

Typical GTC250A-TC Configuration—Networked Control Strategy

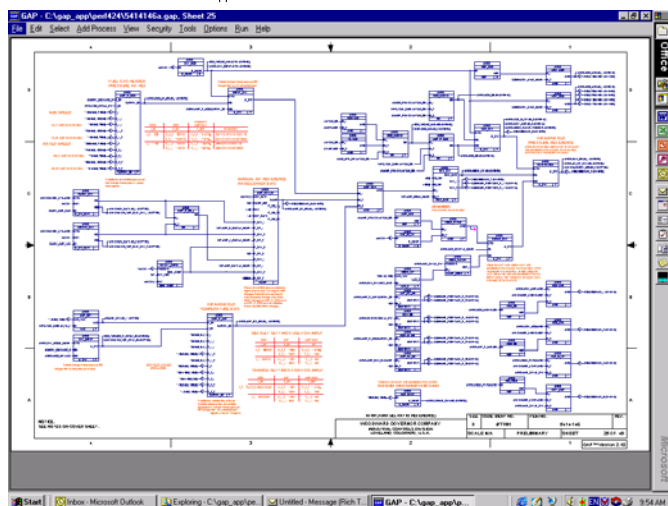
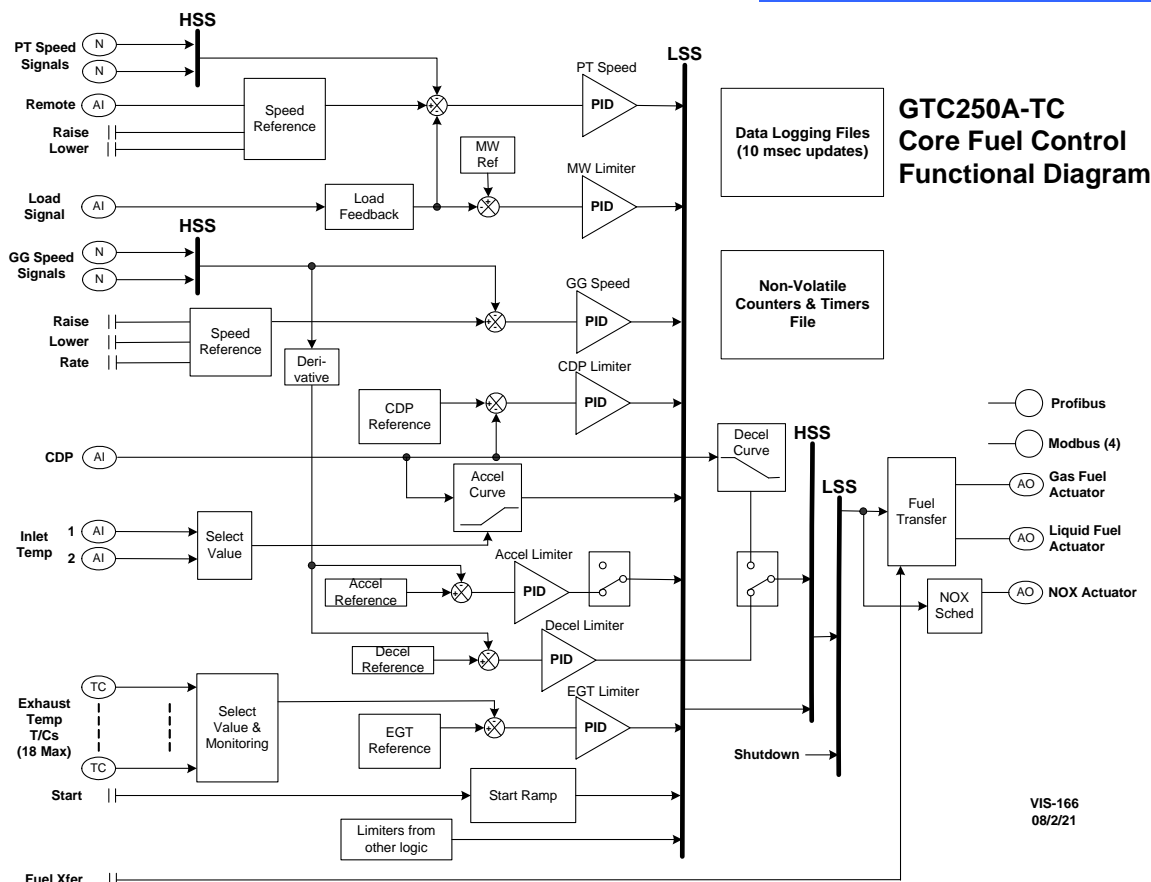

Woodward GAP Programming Environment

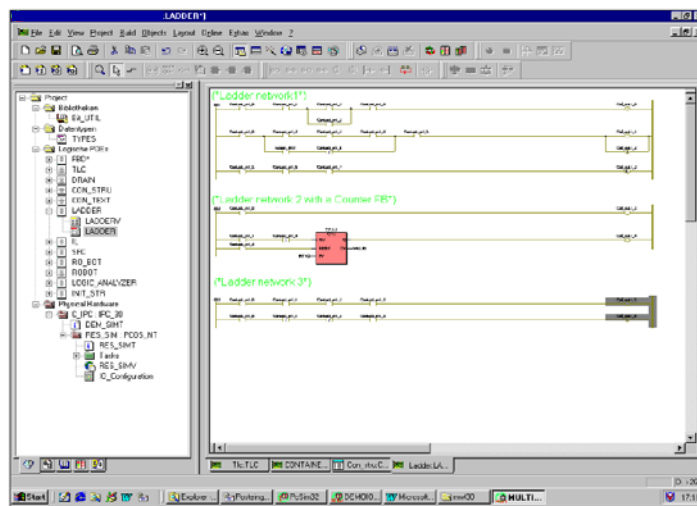

Woodward PLC-Sequencing Programming Environment

Engineering and Service Access

Woodward's software service tools provide service personnel with extensive monitoring and troubleshooting for the GTC250A-TC. The service tools provide operational and analytical information such as graphical display of operating data, data logging (at rate group resolution), trending, event logging, X-Y plotting, and other features.

The following software tools come standard with the GTC250A-TC:

- Read Only GAP—Provides visibility of the GAP (Graphical Application Program) functional blocks and logic.
- Woodward Ladder Logic—Basic Ladder Logic functions that can be used with the GTC250A-TC to add start/stop sequencing and site-specific control logic.
- Application Manager and Other Engineering Interface Tools—Ethernet access to the control for program loading, network configuration and support, and system diagnostics
- Remote Access—Remote connectivity is inherent in the operating system of the control system. Remote viewing, access and diagnostics are as close as a network or a modem.

Other useful software tools (licensing required):

- GAP Editor—Provides the ability to modify the GAP application software, excluding the core fuel control logic.
- Monitor GAP—Ethernet access to view and edit actual run-time values superimposed on the GAP logic.
- Control Assistant—Ethernet connection to Windows-based viewing of high-speed data log captures and other useful utilities; including trending, tunable maintenance.

GTC250A-TC Control System Modules

A5200 SmartCore Module

- Powerful Freescale MPC5200 CPU
- 2 configurable RS-232, RS-422, or RS-485
- 4 Ethernet communication ports
- 2 CANopen communication ports
- 2 MPU/proximity
- 24 discrete inputs
- 6 analog inputs (4–20 mA)
- 4 analog outputs (4–20 mA)
- 2 actuator outputs (4–20 mA, 20–200 mA)

Primary Power Supply

- 18–32 Vdc
- 12 relay drivers
- Optional external relay module with 12 Form C relays (5441-699) and interface cable (5417-747)

Profibus Communications Module

- 12 MBaud Profibus DP master/slave

Analog Input/Output per Module (3 modules)

- 2 MPU speed pickups
- 4 RTD (100 or 200 ohm, 3 wire) /4–20 mA inputs (software selectable)
- 11 thermocouple (E, J, K, N, R, S, T) / analog inputs (4–20 mA) (selectable)
- 2 analog outputs (4–20 mA)
- On-board cold junction sensor

Regulatory Compliance

North American:

- UL: UL Listed for Class I, Division 2, Groups A, B, C, & D, T3C at 70 °C surrounding air temperature. For use in Canada and the United States.
UL File E156028

European Compliance for CE Marking:

- EMC Directive: 2004/108/EC
Low Voltage Directive: 2006/95/EC
ATEX Directive: 94/9/EC (Zone 2, Cat. 3, Group II G, Ex nA IIC T3 X)

Marine Compliance

Models are available that are suitable for marine applications.

- ABS: ABS Rules 2006 SVR 4-2-1/7.3, 7.5.1, 7.9.3/174-9-7/Table 9
DNV: Standard No. 2.4, 2006: Temp. Class B, Hum. Class B, Vib. Class C, and EMC Class A
LRS: Test Specification No. 1, 2002: ENV1, ENV2, and ENV3

Environmental Specifications

Skid Mount Packaging

- Operating temperature: –20 to +70 °C (+60 °C w/ Profibus in GTC250A-TC)
- Storage temperature: –40 to +85 °C
- Vibration: Lloyds Test Specification No. 1, 2002, Vibration Test 1 (5–13.2 Hz, ±1 mm; 13.2–100 Hz, ±0.7 g)
- Shock: US MIL-STD-810C, 516.2-2 (30 g, 11 ms, 1/2 sine)
- Marine Type Approvals: ABS, DNV, LRS



PO Box 1519, Fort Collins CO, USA 80522-1519
1000 East Drake Road, Fort Collins CO 80525
Tel.: +1 (970) 482-5811 • Fax: +1 (970) 498-3058
www.woodward.com

Distributors & Service

Woodward has an international network of distributors and service facilities. For your nearest representative, call the Fort Collins plant or see the Worldwide Directory on our website.

This document is distributed for informational purposes only. It is not to be construed as creating or becoming part of any Woodward contractual or warranty obligation unless expressly stated in a written sales contract.

© Woodward 2007, All Rights Reserved

For more information contact:

2011/4/Colorado