

PROTECTION MADE SIMPLE.

HighPROTEC

MRI4 COMBINED NON-DIRECTIONAL OVERCURRENT AND EARTH-FAULT RELAY

The MRI4 is a protection relay which uses the latest Dual-Core-Processor Technology to provide precise and reliable protective functions and is very easy to operate. The MRI4 provides a number of three phase protection elements to safeguard against overcurrent, short-circuit and earth fault, all with inverse time (INV) and definite time (DEFT) tripping characteristics. The MRI4 is also ideal for the protection of isolated, resonant, resistive and solidly earthed neutral systems. It is designed to be used in both radial networks and single fed open ring main systems. It can also serve as backup protection for differential protection systems on generators, transformers, bus bars and electrical lines. For overhead line protection the MRI4 is also available with an optional auto reclosing function. The protection functions of the MRI4 have been adapted to comply with the requirements of the VDE-AR-N-4110:2018.



New Features - Release 3.7

- ▶ Improved design of the PC tools
- ▶ Configurable SCADA protocols: Modbus, Profibus, IEC 60870-5-103/-104, DNP3

All HighPROTEC devices have been type tested and fully certified by KEMA Laboratories (IEC 60255-1:2009).

All Inclusive:

- ▶ All protection features without extra charge
- ▶ Parameter setting and evaluation software
- ▶ Disturbance record analysis software

Six Elements phase overcurrent protection ⁽¹⁾

- ▶ Non-directional overcurrent/short-circuit protection (DMT/IMDT)
- ▶ Tripping characteristics: DEFT
ANSI: MINV, VINV, EINV
IEC: NINV, VINV, LINV, EINV
Thermal Flat, IT, I2T, I4T

Four Elements Earth Fault Protection ⁽²⁾

- ▶ Non-directional earth fault protection (DEFT/INV)
- ▶ Tripping characteristics: DEFT
ANSI: MINV, VINV, EINV
IEC: NINV, VINV, LINV, EINV
Thermal Flat, IT, I2T, I4T
RXIDG
- ▶ Wattmetric Ground Fault Protection

Power Quality

- ▶ THD protection

Demand Management/ Peak Values

- ▶ Current (peak values) and average current

Supervision

- ▶ Current transformer supervision
- ▶ Circuit breaker failure protection

- ▶ Trip circuit supervision
- ▶ Cold load pickup
- ▶ Switch onto fault

Additional Highlights

- ▶ Two Elements Unbalanced Load Protection
- ▶ Automatic reclosing
- ▶ Inrush
- ▶ Thermal replica
- ▶ Plausibility checks
- ▶ Adaptive parameter sets
- ▶ Status display
- ▶ Comprehensive RMS and DFT measured values and statistics
- ▶ Masking of unused functions
- ▶ Multi-Password-Level

Recorders

- ▶ Disturbance recorder: 120 s non volatile
- ▶ Fault recorder: 20 faults
- ▶ Event recorder: 300 events
- ▶ Trend recorder: 4000 non volatile entries

PC Tools

- ▶ Setting and analyzing software
Smart view for free
- ▶ Including page editor to design own Control pages
- ▶ SCADApt to re-assign datapoints for Retrofit projects: Modbus, Profibus, IEC 60870-5-103/ -104

Control

- ▶ 1 breaker
- ▶ Breaker wear

Commissioning Support

- ▶ USB connection
- ▶ Customizable Display (Single-Line)
- ▶ Customizable Inserts
- ▶ Copy and compare parameter sets
- ▶ Configuration files are convertible
- ▶ Forcing and disarming of output relays
- ▶ Integrated fault simulator
- ▶ Graphical display of tripping characteristics
- ▶ 8 languages selectable within the relay

Communication Options

- ▶ IEC 61850
- ▶ Profibus DP
- ▶ Modbus RTU and/or Modbus TCP
- ▶ IEC 60870-5-103
- ▶ IEC 60870-5-104
- ▶ DNP 3.0 (RTU, TCP, UDP)
- ▶ SCADApt

Cyber Security

- ▶ Menu for the activation of security settings (e. g. hardening of interfaces)
- ▶ Security Logger
- ▶ Centralized Security Logs (Syslog)
- ▶ Encrypted Connection Smart view - Device
- ▶ Device specific certificates (No man in the middle attacks)

Logic

- ▶ Up to 80 logic equations for protection, control and monitoring

Time Synchronisation

- ▶ SNTP, IRIG-B00X, Modbus, DNP 3.0, IEC 60870-5-103/-104

(1) DFT, True RMS or I2 based

(2) DFT or True RMS based

Functional Overview

Protective Functions		ANSI	IEC 61850
I, time overcurrent and short circuit protection, multiple reset options (instantaneous, definite time, reset characteristics according to IEC and ANSI)	6	50P, 51P	PTOC
Negative phase sequence overcurrent protection		51Q	PTOC
I2>, unbalanced load protection with evaluation of the negative phase sequence currents	2	46	PTOC
ThA, overload protection with thermal replica and separate pick-up values for alarm and trip functions	1	49	PTTR
IH2/In, inrush detection with evaluation of the 2nd harmonic	1	Inrush	PHAR
IG, earth overcurrent and short circuit protection	4	50N/G, 51N/G	PTOC
AR, automatic reclosing	1	79	RREC
ExP, External alarm and trip functions	4		GAPC
Control and Logic			
Control, Position indication, supervision time management and interlockings for 1 breaker			CILO, CSWI, XCBR, XSWI
Logic: Up to 80 logic equations, each with 4 inputs, selectable logical gates, timers and memory function			
Supervision Functions			
CBF, circuit breaker failure protection	1	50BF	RBRF
TCS, trip circuit supervision	1	74TC	SCBR
CTS, current transformer supervision	1	60L	
CLPU, cold load pickup	1		
SOTF, switch onto fault	1		PSOF
Demand management and peak value supervision			
THD supervision			
Breaker wear with programmable wear curves			
Recorders: Disturbance recorder, fault recorder, event recorder, trend recorder			RDRE

Dimensions of the Device Variant for Door Mounting

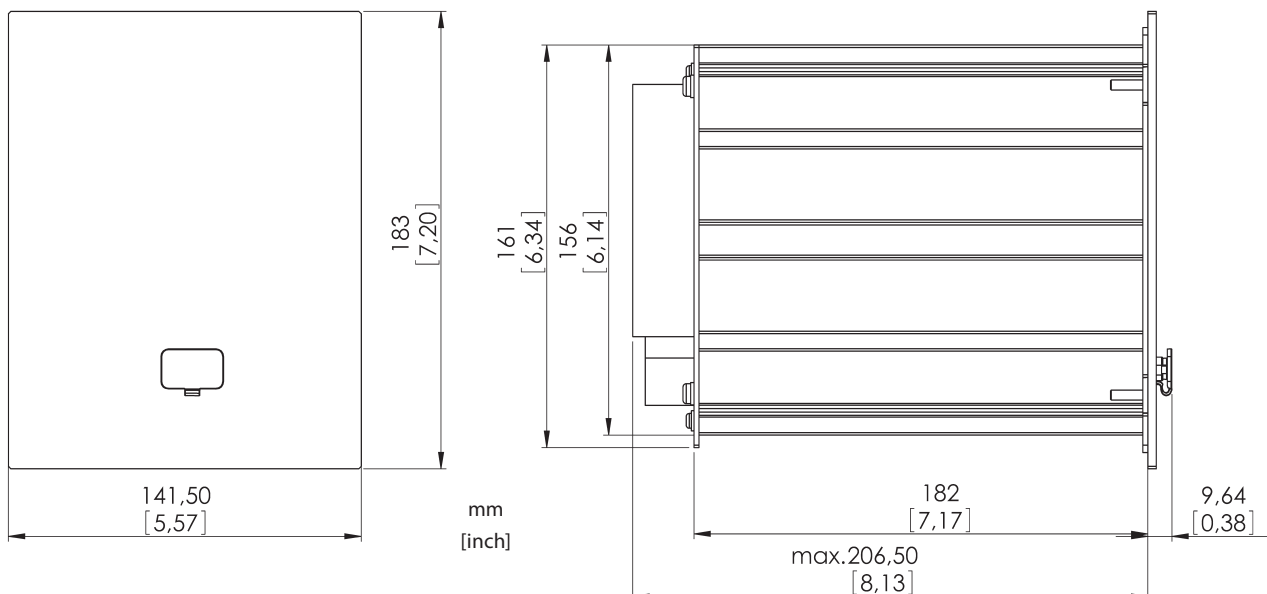

Functional Overview in ANSI / IEEE C37.2 Form

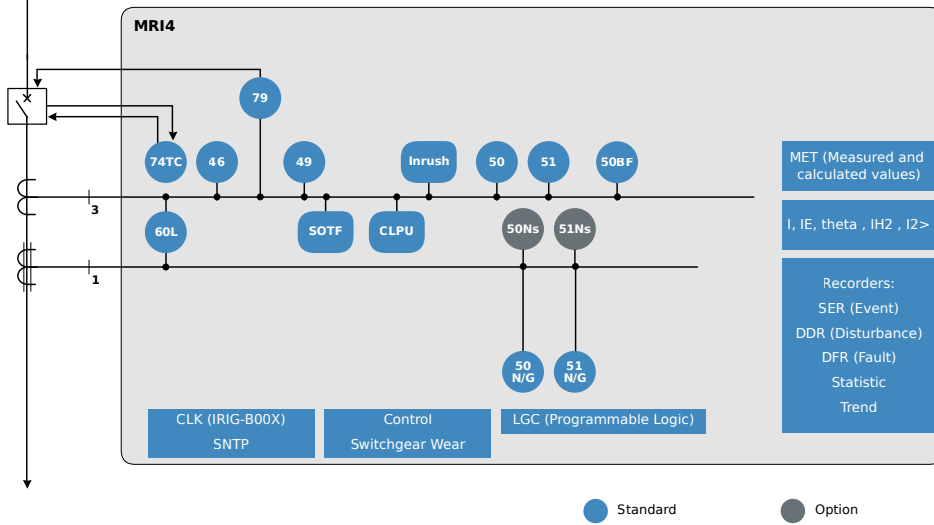

19 " Variants Available!

See Order Form on page 4,
housing type "rack mounting"



<https://docs.SEGelectronics.de/hpt-2>

Terminals Available Separately!

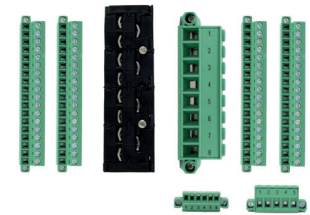

Order codes HPTTERMKIT-1 ... -5
For MRI4: HPTTERMKIT-1
The terminal kits allow for making
all required wirings in advance,
thus speeding up the installation
and commissioning work.

Connections (Example)

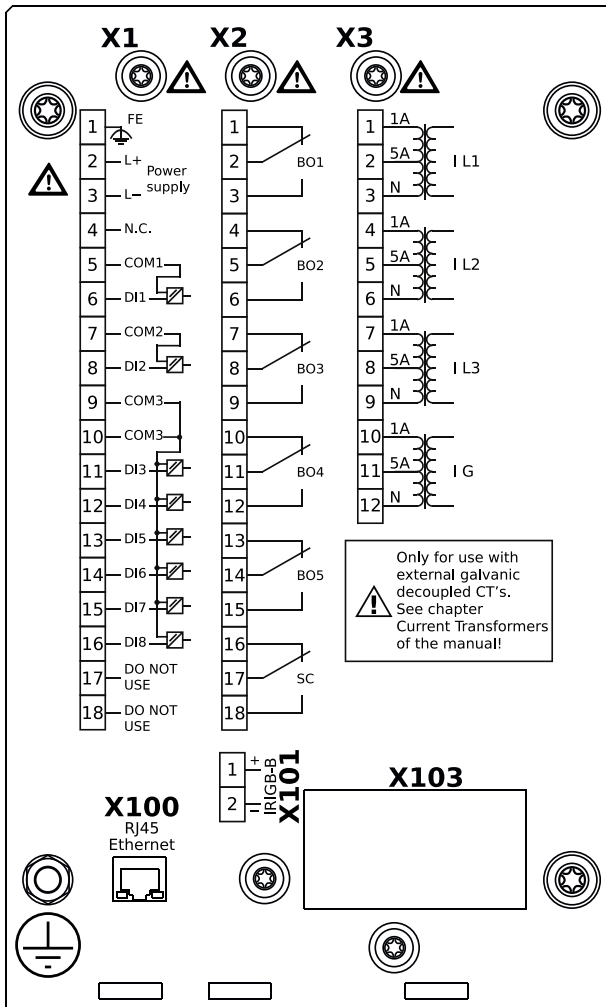

Approvals / Standards



certified regarding UL508
(Industrial Controls)

certified regarding
CSA-C22.2 No. 14
(Industrial Controls)

certified by EAC
(Eurasian Conformity)

Type tested and certified by KEMA Laboratories in
accordance with the complete type test
requirements of IEC 60255-1:2009.

Fulfills the requirements of the German grid code
standard VDE-AR-N 4110 (2018-11)

Complies with IEEE 1547-2003.

Amended by IEEE 1547a-2014.

Complies with ANSI C37.90-2005.

PROTECTION MADE SIMPLE.

Order Form MRI4

Non-Directional Feeder Protection				MRI4	-2				
Version 2 with USB, enhanced communication and user options									
Digital Inputs	Binary output relays	Housing	Large display						
8	6	B1	-	A					
Hardware variant 2									
Phase Current 5 A/1 A, Ground Current 5 A/1 A				0					
Phase Current 5 A/1 A, Sensitive Ground Current 5 A/1 A				1					
Housing and mounting									
Housing suitable for door mounting								A	
Housing suitable for 19" rack mounting								B	
Communication protocol									
Without protocol								A*	
Modbus RTU, IEC60870-5-103, DNP3.0 RTU RS485/terminals								B*	
Modbus TCP, DNP3.0 TCP/UDP, IEC60870-5-104 Ethernet 100 MB/RJ45								C*	
Profibus-DP Optical fiber/ST-connector								D*	
Profibus-DP RS485/D-SUB								E*	
Modbus RTU, IEC60870-5-103, DNP3.0 RTU Optical fiber/ST-connector								F*	
Modbus RTU, IEC60870-5-103, DNP3.0 RTU RS485/D-SUB								G*	
IEC61850, Modbus TCP, DNP3.0 TCP/UDP, IEC60870-5-104 Ethernet 100MB/RJ45								H*	
IEC60870-5-103, Modbus RTU, DNP3.0 RTU RS485/terminals								I*	
Modbus TCP, DNP3.0 TCP/UDP, IEC60870-5-104 Ethernet 100 MB/RJ45								K*	
IEC61850, Modb. TCP, DNP3.0 TCP/UDP, IEC60870-5-104 Opt. Eth. 100MB/LC duplex conn.								L*	
Modbus TCP, DNP3.0 TCP/UDP, IEC60870-5-104 Opt. Ethernet 100MB/LC duplex connector								T*	
IEC60870-5-103, Modbus RTU, DNP3.0 RTU RS485/terminals									
IEC61850, Modbus TCP, DNP3.0 TCP/UDP, IEC60870-5-104 Ethernet 100 MB/RJ45									
Harsh Environment Option									
None								A	
Conformal Coating								B	
Available menu languages (in every device)									
English / German / Spanish / Russian / Polish / Portuguese / French / Romanian									

* Within every communication option only one communication protocol is usable.
 Smart view can be used in parallel via the Ethernet interface (RJ45).
 The parameterizing- and disturbance analyzing software Smart view can be used without extra costs.

Current inputs	4 (1 A and 5 A) with automatic CT Disconnect
Digital Inputs	Switching thresholds adjustable via software
Power supply	Wide range power supply 24 V _{DC} - 270 V _{DC} / 48 V _{AC} - 230 V _{AC} (-20/+10%)
Terminals	All terminals plug type
Type of enclosure	IP54
Dimensions of housing (W x H x D)	19" flush mounting: 141.5 mm x 173 mm x 208 mm 5.571 in. x 6.811 in. x 8.228 in. Door mounting: 141.5 mm x 183 mm x 208 mm 5.571 in. x 7.205 in. x 8.228 in.
Weight (max. components)	approx. 2.4 kg / 5.29 lb

Contact:

SEG Electronics GmbH
 Krefelder Weg 47
 47906 Kempen
 Germany

Sales
 Phone: +49 (0) 21 52 145 331
 Fax: +49 (0) 21 52 145 354
 E-Mail: sales@SEGelectronics.de

Service & Support
 Phone: +49 (0) 21 52 145 600
 Fax: +49 (0) 21 52 145 354
 E-Mail: support@SEGelectronics.de

Find Your Local Distributor on
<http://www.SEGelectronics.de>

Technical Documents:
<https://docs.SEGelectronics.de/mri4-2>



For more information please contact: