

# TecJet™ 110

## Intelligent Electronic Gas Metering Valves

### Description

Efficiency, performance, and emissions. In today's marketplace, these factors play a key role in gas engine development. As engine performance advances are made, gas metering devices should be more flexible and accurate, and be used for a wide range of gas qualities from butane down to landfill gas.

Meet the TecJet™ valve. The TecJet is an electronic gas metering valve for single-point injection. It has integrated sensors and electronics, which provide the correct gas flow under all specified conditions.

In general, a separate engine control system, like the EGS-02 control, calculates the desired gas flow from the different engine and gas parameters. This desired gas flow is transmitted through a CAN link to the TecJet valve(s). The TecJet valve ensures that the desired gas flow is attained, automatically compensating for changes in gas pressure and gas temperature.

The microcomputer inside the TecJet valve converts the desired gas flow signal and gas parameter information into a valve position (which corresponds to the desired gas flow), depending on gas inlet pressure, gas temperature, and the pressure difference across the valve.

### Benefits

Flexible inputs to use the engine control system of an OEM. Communication in two directions possible with other control systems by means of the integrated CANbus.

Fast response to flow commands, which makes it possible to accept large load steps without losing engine speed.

High turn-down ratio that makes it possible to use one TecJet model for a complete engine family, 6 to 24 cylinders.

### Application

The TecJet valve, together with an engine control system, form an ideal combination for operating gas engines with a gas specific gravity from 0.4 to 2.0. The TecJet 110 gas control valve is applicable for stationary applications within a power range of 650–2000 kW for low-BTU specialty gas and 1300–3000 kW for pipeline-quality natural gas. These ranges are also dependent on other factors such as fuel pressure, fuel differential pressure across the valve, fuel temperature, etc. Consult the applicable TecJet Installation and Operation manual or a Woodward application engineer for actual sizing of a valve.

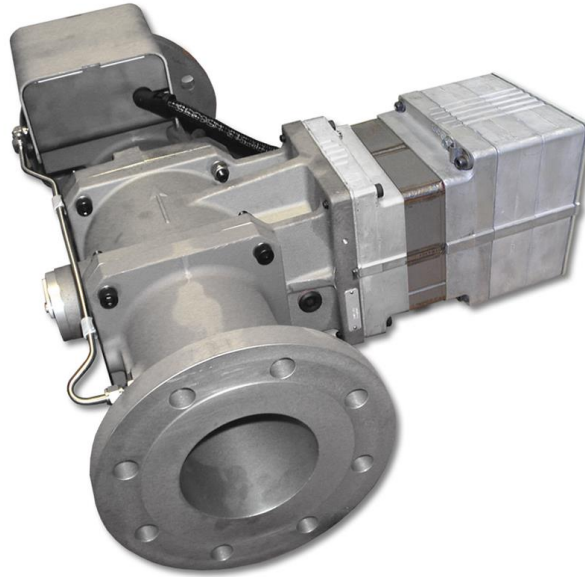

- Forms ideal combination with EGS-02 control
- Bi-directional communication via CANbus, CANopen, J1939, or custom CAN
- Microprocessor based mass gas flow control
- Communication in two directions by CANbus
- Fast response to flow commands
- Accurate over entire flow range
- Flow testing ensures that the engine does not have to be recalibrated if TecJet is replaced
- Compensates for gas pressure and gas temperature fluctuations
- Integrated sensors and electronics
- Requires only analog or digital desired gas flow signal and supply voltage

The TecJet gas control valve is typically installed upstream of the turbo. The TecJet has a fast response to handle variations in engine load and speed. This is important for good engine behavior, low fuel consumption, low emissions and load changes. With the help of a PC (personal computer), you can easily monitor and set up the TecJet valve for your specific application.

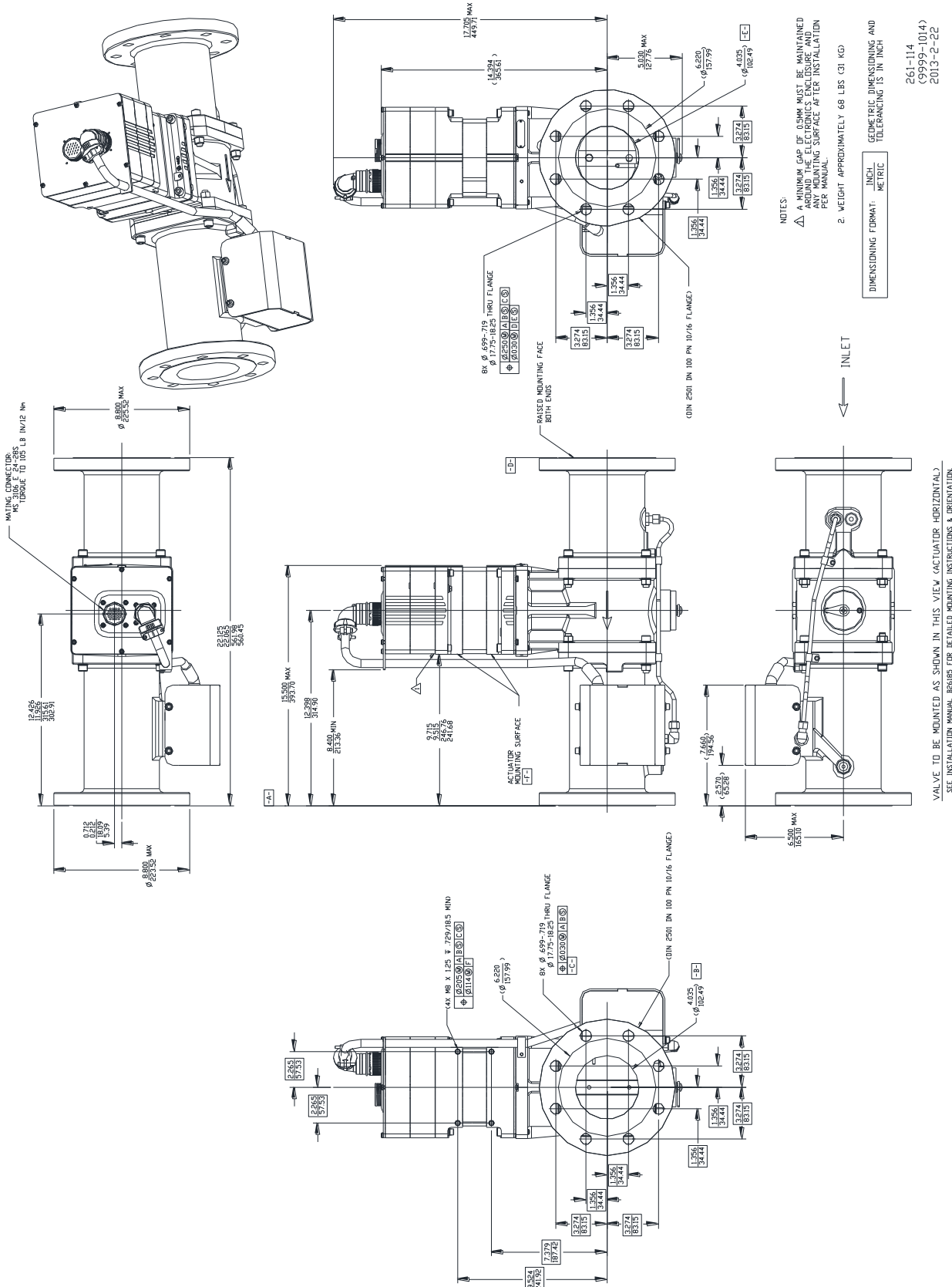

261-114  
(9999-1014)  
2013-2-22

VALVE TO BE MOUNTED AS SHOWN IN THIS VIEW (ACTUATOR HORIZONTAL).  
SEE INSTALLATION MANUAL BEGINS FOR DETAILED MOUNTING INSTRUCTIONS & ORIENTATION.

TecJet 110 Outline Drawing

## Specifications

---

Weight:	31 kg (68 lb)
Size:	105 mm
Valve Maximum Geometric Area:	6065 mm <sup>2</sup> (9.4 in <sup>2</sup> )
Input Voltage Range	18–32 Vdc
Input Current Range:	<=4.0 steady state, 13.0 peak
Temperature Ranges	
Steady State Ambient:	–20 to +85 °C (–4 to +185 °F)
Long Term Storage:	–40 to +40 °C (–40 to +104 °F)
Short Term Storage:	–40 to +105 °C (–40 to +221 °F)
Fuel Gas Inlet:	0 to +65 °C (+32 to +149 °F)
Pressure Ranges	
Fuel Gas Inlet:	50 to 276 mbar gauge (0.73 to 4 psig)
Inlet to Outlet Delta:	70 to 276 mbar (1 to 4 psid)
Filter in the Gas Stream	Maximum mesh size 50 µm
Flow Accuracy*	±20% point accuracy: Crank to Idle flow rate ±10% point accuracy: Idle to 25% valve maximum rated mass flow ±6% point accuracy: >25% valve maximum rated mass flow
Dynamics	
Position Response:	–3 db at > 7 Hz, with 1400%/second slew rate limit, 2 ms dead time. Overshoot < 1%
Demanded Flow Response:	Same as position loop response with addition of 3 ms flow loop update rate
Pressure Change Rejection:	Same as demanded flow response with addition of 10 ms lag on P1 measurement, 100 ms lag on delta pressure
Vibration	Random Vibration: Exceeds WGC RV2, 10–2000 Hz @ 0.1 G <sup>2</sup> /Hz (12.8 Grms)
Shock	Per US MIL-STD-810C, Method 516.2, Procedure 1 (40 g)
Communication/Command Signals	CAN PWM: 7 to 32 V differential input, 12 bit resolution, 40 kΩ impedance 4 to 20 mA Analog: 225 Ω impedance, differential, 25 mA ±2% max input current Customer specific input

(\*) Add an additional 1.5%, 1%, and 0.5%, respectively, to flow accuracy values listed if inlet to outlet delta is greater than 276 mbar (4 psid).

*TecJet Service Tool* can be downloaded from the Web at [www.woodward.com/software](http://www.woodward.com/software). Select software product “TecJet Tools”, then follow the installation instructions given on that page.

*Technical Manual: 26185*

For information about the smaller **TecJet 52** (52mm), please see product specification 03355.

## Regulatory Compliance

---

### European Compliance for CE Marking:

**EMC Directive:** Declared to Directive 2014/30/EU of the European Parliament and of the Council of 26 February 2014 on the harmonization of the laws of the Member States relating to electromagnetic compatibility (EMC)

Product also complies with the Machinery and Pressure Equipment Directives.

### North American Compliance:

**CSA:** CSA Certified for use in Class I, Division 2, Groups A, B, C, and D T3 for United States and Canada as a component for use in other equipment.

## Adjustments

Using the TecJet Service Tool installed on a laptop or PC connected to the TecJet valve, you can monitor and make adjustments quickly and easily through the following six tabs:

### Overview Tab

The Overview Tab contains flow demand, gas pressures, gas temperature, and gas property information.

### Troubleshooting Tab

The Troubleshooting Tab contains typical valve information used for troubleshooting purposes. This information includes electronics temperature, supply voltage, running hours, and CAN communication info.

### Warnings Tab

The Warnings Tab displays valve warning indicators. When one of these warnings occurs, the valve continues to operate, but the valve Status Output switches to signal the operator that a problem has occurred.

### Errors Tab

The Errors Tab displays valve error indicators. When one of these errors occurs, the valve goes into shutdown mode, and the valve status output switches to signal the operator that a problem has occurred.

### Configuration Tab

The Configuration Tab allows the user to customize the valve to a particular application. CAN parameters, demand signal scaling, warning/error limits, default pressures, and demand source can all be viewed or changed on this tab.

### Identification Tab

The Identification Tab contains valve and software information such as part numbers and serial numbers.

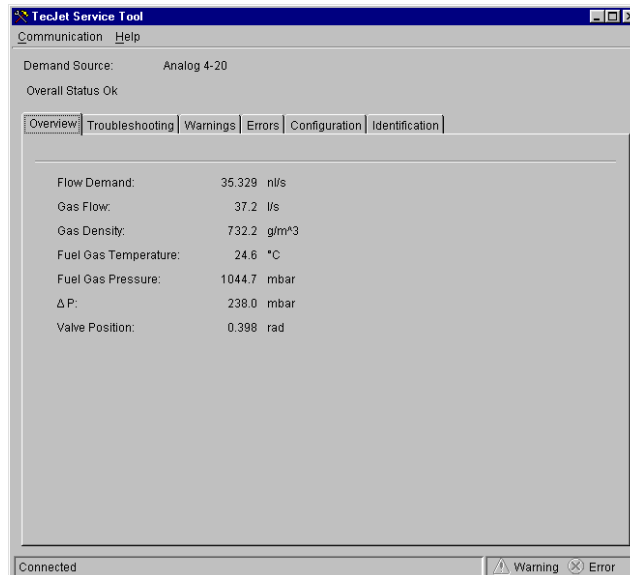

**TecJet Monitoring Program**



PO Box 1519, Fort Collins CO, USA 80522-1519  
 1000 East Drake Road, Fort Collins CO 80525  
 Tel.: +1 (970) 482-5811 ♦ Fax: +1 (970) 498-3058  
[www.woodward.com](http://www.woodward.com)

#### Distributors & Service

Woodward has an international network of distributors and service facilities. For your nearest representative, call the Fort Collins plant or see the Worldwide Directory on our website.

This document is distributed for informational purposes only. It is not to be construed as creating or becoming part of any Woodward contractual or warranty obligation unless expressly stated in a written sales contract.

Copyright © Woodward 2003–2016, All Rights Reserved

For more information contact: